

Ready...set...HITCH!

Ready...

Back into Hitch-ezy

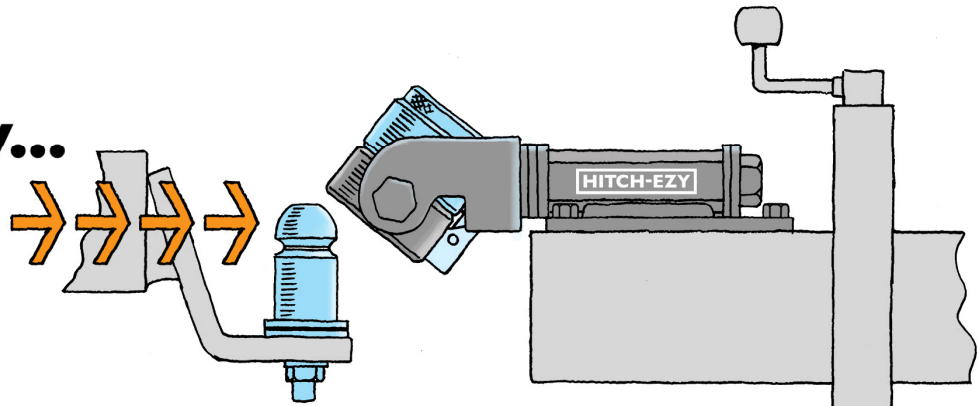

set...

Hitch-ezy rolls onto the pillar.

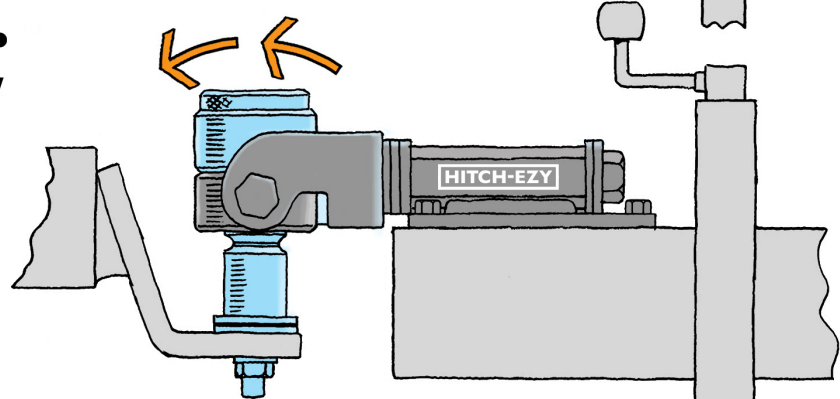

HITCH!

Unlock and lower Hitch-ezy fully down the pillar. Double-locks automatically upon engagement.

Uncoupling:

Hitch-ezy releases smoothly under any load.

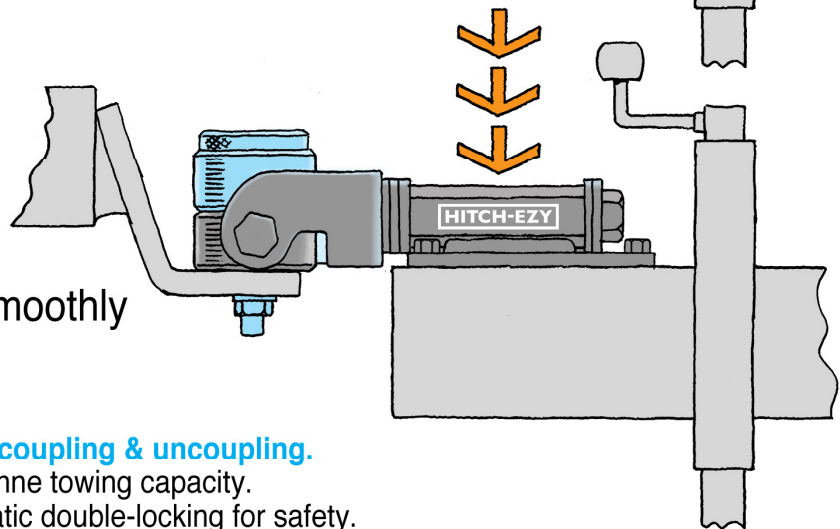

Your passport to hassle-free coupling & uncoupling.

- ✓ Unlimited articulation. ✓ 5 tonne towing capacity.
- ✓ Rattle-free towing. ✓ Automatic double-locking for safety.
- ✓ Accepts a padlock for security.
- ✓ Built tough to handle harsh outback conditions.
- ✓ Static and dynamic tested for ADR 62/02 compliance.
- ✓ Sealed against dust and water.
- ✓ Low profile for rear door clearance.
- ✓ Arthritis-aid allows unlocking with one finger.
- ✓ 'Keep-it-clean' pillar cover and coupling cover.
- ✓ Adapter available for use with level-ride torsion bars.
- ✓ 'Disable key' allows 2 handed jockey wheel operation.
- ✓ Standard bolt pattern allows easy retro fitting.

hitch-ezy@bigpond.com
www.hitch-ezy.com.au
Tel 0407 246 407



Hassle-free coupling
and uncoupling

Trade enquiries welcome.